

EF65 1620

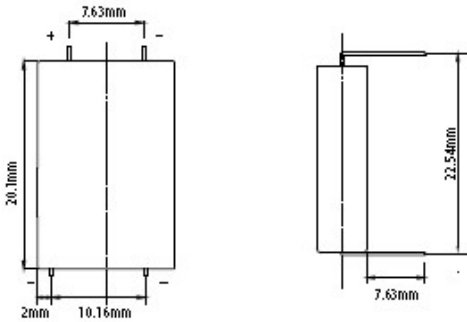

SPECIFICATION: (23±2°C)

Nominal capacity (1mA~2V):	550mAh
Rated voltage:	3.6V
Max constant current of discharge:	10mA
Max discharge current(pulse):	20mA
Weight:	6g
Operating temperature range:	-55~85°C

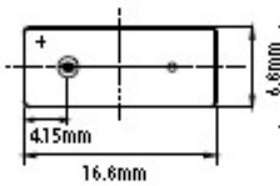

S: Standard termination

Notes:

Dimension: mm

Special terminations can be made as requested.

T: Solder tabs

P: Axial pins

Important Notes

Do not short or charge the battery.

Over-discharging, crushing, incinerating, and disassembling the battery are prohibited.

Do not heat/use the battery beyond the permitted temperature range.

Discharge characteristics at 23±2°C

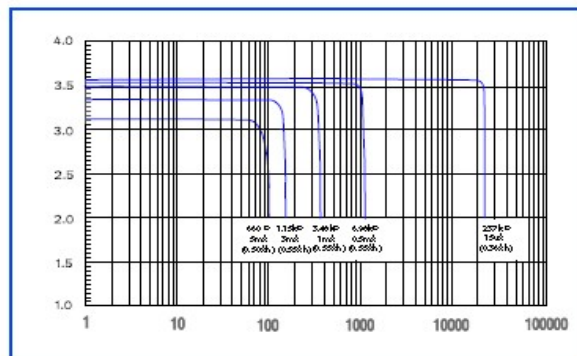

Capacity VS. Current

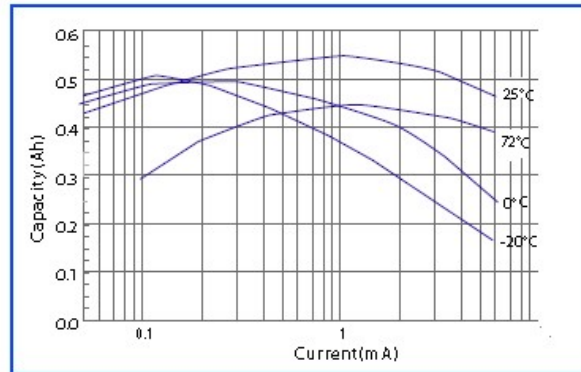

Voltage VS. Temperature

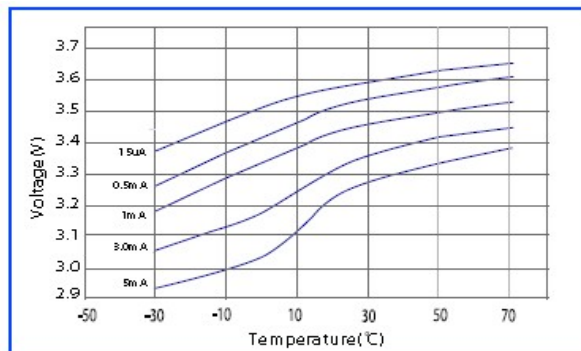

Guangzhou Markyn Battery Co., Ltd.

YiJia Industrial Park, Shixin Road 1100, Nancun Town, Panyu District, Guangzhou P.R.C

Tel:(86)20 — 8456 0852 Fax:(86)20 — 3476 7936

Email:sale s@gmbattery.com

U.L. Component Recognition MH 45782