



GUANGZHOU MARKYN BATTERY CO., LTD.

Specification Approval Sheet

Name : Lithium Polymer Battery

Model : 7567270FS

SPEC : 24V (8S1P) /10Ah

Number: GMB1003240033

Approved By	Checkup	Make

Customer Confirmation	Signature	Date
	Company Name :	
	Stamp :	

ADD: Block2, Haijin Road6, Markyns Industrial Zone, XinZao
Town, Panyu District, Guangzhou City, P.R.C.

Tel: +86-20-84720852

Fax: +86-20-84720936

POLYMER LITHIUM BATTERY DATA SHEET

FILE No.: **GMB021709/LIPO**

Content

1.Scope	4
2.ModelType	4
3.Specification	4
4.Battery Cell Performance Criteria	5
5.Storage and others	7
6.Drawing(not in scale).....	8
Handling Precautions and Guideline	10
1.Charging	10
2.Discharging	10
3.Discharging Temperature	11
4.Over-Charged	11
5.Protection Circuit Module(PCM)	11
6.Storage	11
7.Notice for Designing and Assembling Battery Pack.....	11
8.Other Notice.....	13
▲ Special Notice	13

Any copies are invalid without our company's approval

POLYMER LITHIUM BATTERY DATA SHEET

FILE No.: **GMB021709/LIPO**

1.Scope:

This document describes the Product Specification of chargeable Lithium Polymer Battery produced by Guangzhou Markyn Battery Co., Ltd.

2.Model: 7567270FS

3.Cell parameters Index:

3.1 Single cell parameters

No.	Item	Spec	Note
1	Model	7567270FS/10Ah	
2	Charge Voltage	3.65V	
3	Nominal Voltage	3.3V	Cell Voltage between 3.2V ~3.4V before shipping
4	Nominal Capacity	≥10Ah@ 0.2C Discharge	Nominal Capacity refer to the capacity of 0.2C discharge with 2.0V cut-off voltage, after charging with standard method.
5	Cycle Life	≥ 1000 Times	One cycle refer to one charge period and then one discharge period. Test condition: Charge:0.2C to 3.65V Discharge: 0.2C to 2.0V The cycle life is the cycle times when the discharge capacity is about 80% of the rated capacity.
6	Self-discharge	Residual Capacity>90%	After standard charging, storied at 25°C±5°C for 30 days, then measure the capacity as Iteme4.
7	Impedance	≤8mΩ	After Standard charging, measure the internal resistance with AC1KHz(while measuring, clip near 2/3 place of the anode and the cathode.)
8	Max. Charge Current	1.0C	
9	Max. Discharge Current	1.0C	
10	Discharge Cut-off Voltage	2.0V	
11	Operating Temperature	Discharge:-10°C~ +60°C Charge: 0 °C~ +45°C	Cells must be stored at 3.2V-3.4V. Over long storage periods cells should be cycled every 90 days. The method is to do a charge-discharge cycle with standard method, then charge to 3.2—3.4V.
12	Storage Temperature	-20 °C~+45°C	Voltage:3.3±0.1V
13	Cell Weight	Approx 0.28Kg	
14	Cell Dimension	Length: 272mm Max Width: 69mm Max Thickness: 7.9mm Max	

POLYMER LITHIUM BATTERY DATA SHEET

FILE No.: **GMB021709/LIPO**

3.2 Standard of a pair of cells

- The difference of two cells' open Voltage is less than 50mV.
- The difference of two cells' impedance is less than 5 mΩ.
- During discharge period with same discharge conditions, at anytime, the difference of two cells' capacities is less than 30mAh.

3.3 Parameters of pile

No.	Items	Spec.	Notes
1	Rated Capacity	≥10Ah	@ 0.2CmA discharging
2	Nominal Voltage	24V	The average value of voltage during the discharge period (with standard charge and discharge).
3	Impedance	≤140mΩ	measure two sides of the drawing line after assembling. (Red B+, Black B-)
4	Assemblage Dimension	Length: 390mm Width: 87mm Thickness: 86mm	Weight Approx 4.0Kg

Note: if the battery is in series, the internal resistance of PTC will change according to the temperature.

4. Electronic Characteristics test and inspection:

4.1 Standard testing environment

Unless specifically stated otherwise, tests must be done within one month of delivery and the number of charging-recharging cycles is fewer than 5.

Test conditions:

Ambient Temperature: 25°C ± 5°C

Ambient Humidity: 65 ± 20%

4.2 The requirements of measurement instruments

- The measurement instrument has been certified by a qualified source.
- The accuracy of the measuring instrument is at least 0.01mm.
- The accuracy of multimeter is at least 0.5%. While measuring the voltage, the internal resistance can not be less than 10KΩ.
- The principle internal resistance is 1KHz LCR; the accuracy is 0.2%.
- The internal resistance can vary based upon temperature and the charging mode. It is relevant to the PTC and the length and resistance of the wiring.
- The current accuracy of the battery test system is at least ±0.1%, isobarically accuracy is ±0.5%, and timer accuracy is less than ±0.1%.
- The accuracy of the thermometer is at least ±0.5°C.

4.3 Visual inspection

Any visual defects which will affect the electronic characteristics, such as leakage and damage, are not obvious.

4.4 Charge/Discharge Methods and Test Conditions

No.	Item	Testing Condition and Method
1	Charging Current	Standard CC: 0.2C Quick CC: 0.5C
2	Standard Charging	Constant Current Charging at 0.2C to 3.65V. Constant Voltage Charging at 3.65V to cut-off current≤0.05C
3	Quick Charging	Constant Current Charging at 0.5C to 3.65V. Constant Voltage Charging at 3.65V to cut-off current≤0.05C

POLYMER LITHIUM BATTERY DATA SHEET

FILE No.: **GMB021709/LIPO**

4	Standard Discharge	Constant discharge at 0.2C to cut-off voltage of 2.0V.
5	Charging Time	Standard charging time: 8 hours Quick charging time: 2.5 hours
6	Temperature & Humidity	Standard charging: 0°C~ 45°C 45~85% RH Quick charging: 10°C~ 45°C 45~85%RH Standard discharging: -10°C~ 60°C 45~85% RH
7	Open Voltage	3.2~3.4V (before shipping)

Notes: The maximum charging voltage shall not exceed 3.8V. The Max. protection voltage designed into the PCM board must not be more than 3.85V.

4.5 Mechanical Characteristics

No.	Item	Testing Conditions and Method	Standard
1	Vibration Test	After standard charging, the cell is secured to a vibration table and subjected to vibration cycling in which the frequency is varied at the rate of 1Hz per minute between 10Hz and 55Hz; the excursion of the vibration is 0.38mm. The cell shall be vibrated for 30 minutes on each of X, Y, and Z axis.	No leakage. Remaining capacity is ≥90% after 3 hours.
2	Drop Test	The cell is dropped from a height of 1 meter two times onto a concrete surface.	No explosion, fire, or leakage

4.6 Safety Test

No.	Item	Testing Conditions and Method	Standard
1	Over-charge	Charging is conducted for 8 hours while the voltage is held at 10.0V.	No deformation or leakage
2	Short-circuit	The charged battery is short-circuited for 1 hour at 100mΩ.	No explosion or fire
3	Heat shock	The cell is placed in a thermal chamber. Temperature is raised to 120±2°C at the rate of (5±2°C)/min and held for 10 minutes, then cooled to room temperature at the rate of 5±2°C/min.	No explosion or fire
4	Humidity and heat test	A charged battery is placed in a box for 48 hours where the temperature is 40°C±2°C and the relative humidity is 90%~95% .	No smoke or explosion

4.7 High and low temperature test

No	Item	Testing Conditions and Method	Standard
1	High Temperature	A charged battery is placed in an oven for 2 hours at 55°C±2°C, then discharged at a 0.5C current until the voltage is 2.0V.	Discharge 90 percent of the original capacity.
2	Low Temperature	A charged battery is placed in a thermal chamber for 16 to 24 hours at -10°C±2°C; then discharged at 0.1C until 2.0V is reached	Discharge more than 45 percent of the original capacity.

4.8 Electricity maintenance

No	Item	Testing Conditions and Method	Standard
1	Electricity Maintenance	A charged battery sits for 28 days at ambient temperature of 25°C±5°C and is then discharged to the termination voltage.	Discharge more than 85 percent of the original capacity.

POLYMER LITHIUM BATTERY DATA SHEET

FILE No.: **GMB021709/LIPO**

5. Storage and Others

5.1 Longterm Storage

If the cell is to be stored for 3 months or longer it should be held in a dry and cool environment. Voltage during storage needs to be maintained between 3.2V and 3.4V and the storage conditions are the same as Item 4.1.

5.2 Any issues not covered in this specification should be discussed between the customer and Guangzhou Markyn Battery Co., Ltd.

6. Drawing

6.1 Assembly diagram

Model: 7567270FS

Unit: mm



POLYMER LITHIUM BATTERY DATA SHEET

FILE No.: **GMB021709/LIPO**

6.2 Single cell Drawing (Not in scale)

Model: 7567270FS

Unit: mm

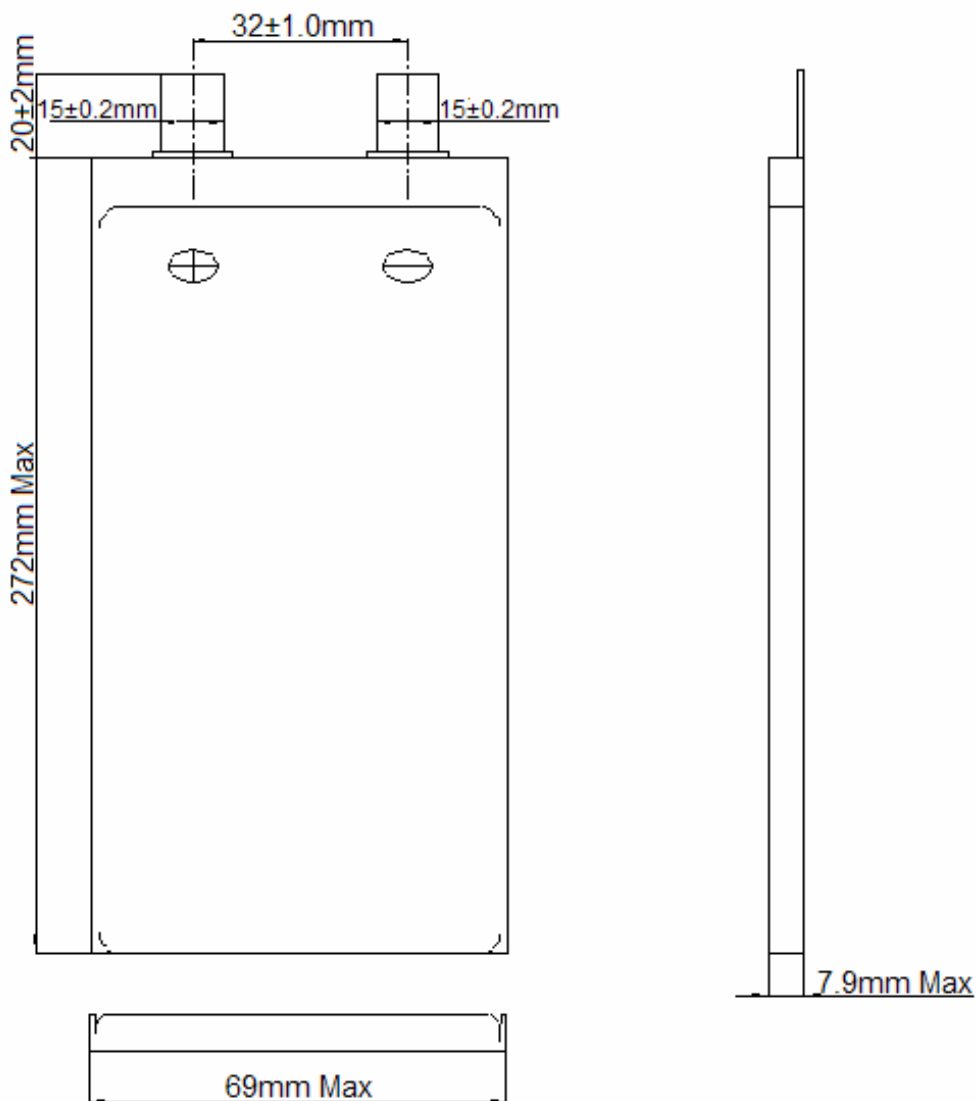

POLYMER LITHIUM BATTERY DATA SHEET

FILE No.: **GMB021709/LIPO**

7.BMS-Specification

7.1Circuit Diagram

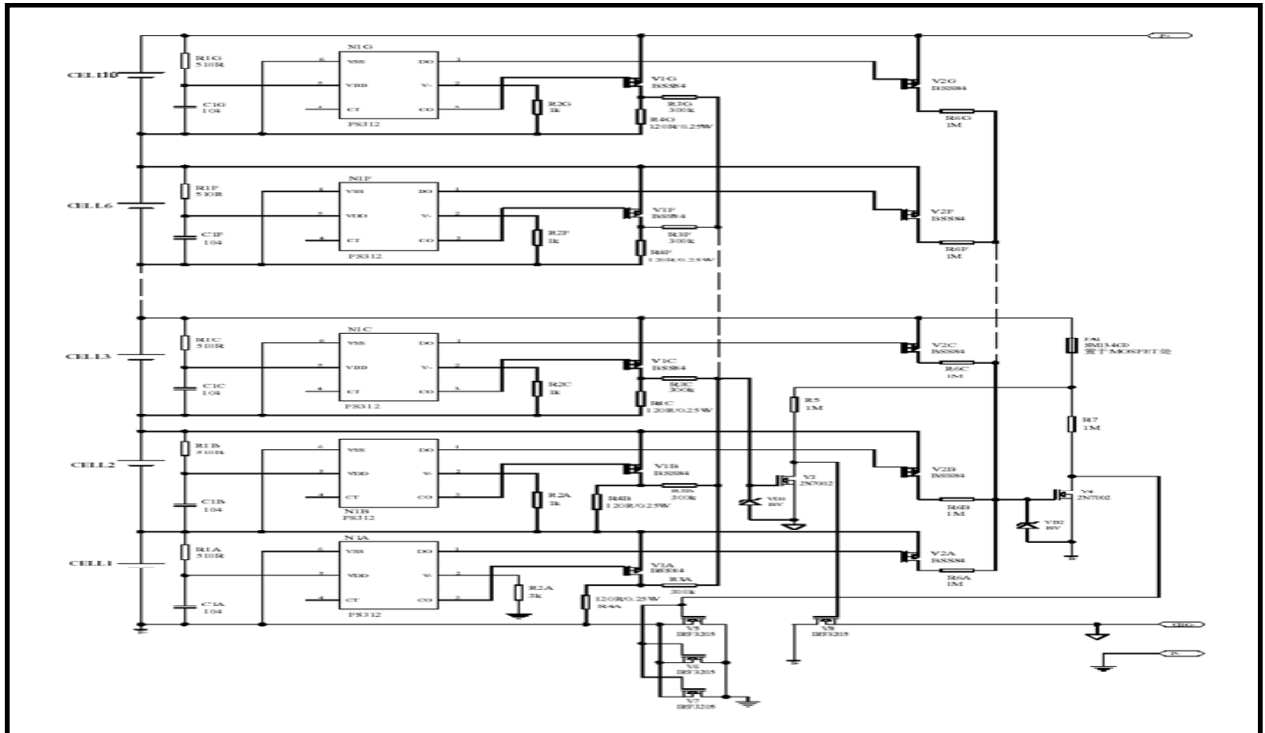





7.2Electronic characteristic

Item	Content	Typical	Unit	Note	
CFG	over charge	over-charge protection for each cell	3.85	V	0~4.998 (+/-10mV)
		over-charge recover protection for each cell	3.5	V	0~4.998 (+/-10mV)
	over discharge	over-discharge protection for each cell	2.0	V	0~4.998 (+/-10mV)
		over-discharge recover protection for each cell	2.5	V	0~4.998 (+/-10mV)
	current	charge over current protection	10	A	adjustable
		discharge over current protection	35	A	adjustable
		normal charging current	15	A	adjustable
	temperature protection /dis- charge	over temperature protection	75	°C	-30°C~90°C
		over temperature protection recover	65	°C	-30°C~90°C
		under temperature protection	-15	°C	-30°C~90°C
		under temperature recover	-5	°C	-30°C~90°C

POLYMER LITHIUM BATTERY DATA SHEET

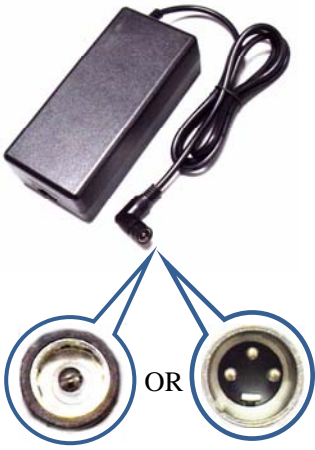
FILE No.: **GMB021709/LIPO**

8. Switching power supply

				
	CHN/AUS	UK	EU	USA
Electrical Specification	Input Characteristics	Nominal Voltage		100-240Vac
		Variation Range		90-264Vac
		Input Frequency		50/60Hz
		Rated Loadinput Current		<1.0A
	Output Characteristics	Voltage		29.2V
		Min. Load		0A
		Max. Load		1.9~2.1A
		Load Regulation		±5%

Handling Precautions and Guidelines

For LIP (Lithium-Ion Polymer) Rechargeable Batteries

Preface

This document of 'Handling Precautions and Guidelines for LIPO Rechargeable Batteries' shall be applied to the battery cells manufactured by Guangzhou Markyn Battery Co., Ltd.

Note (1): The customer is requested to contact GMB in advance if and when the customer needs variations of the operating conditions described in this document. Additional experimentation may be required to verify performance and safety under such conditions.

Note (2): GMB will take no responsibility for any accident when the cell is used under conditions outside of this specification.

Note (3): GMB will inform the customer in writing of improvement(s) regarding proper use and handling of the cell if it is deemed necessary. Guangzhou Markyn Battery Co., Ltd. reserves the right to revise this specification before the customer signs the datasheet. If a revision is required, GMB will notify the customer.

1. Charging

POLYMER LITHIUM BATTERY DATA SHEET

FILE No.: **GMB021709/LIPO**

1.1 Charging Current:

The charging current must be less than the maximum charge current specified in the Specification Approval Sheet.

1.2 Charging Voltage:

The charging voltage must be less than the maximum nominal voltage 3.65V, and the charging voltage upper limit is 3.85V (single pack).

1.3 Charging Temperature:

The cell must be charged within the range specified in this Specification Approval Sheet.

1.4 Notes:

Since charging is done with a constant current or a constant voltage, reverse charging is prohibited. If the cell is connected improperly it cannot be charged. Reverse charging can damage the cell and lead to degradation of cell performance, impair cell safety, and cause heat generation or leakage.

2. Discharging Current:

The cell shall be discharged at less than the maximum discharge current specified in the Specification Approval Sheet. A high discharging current may reduce the discharge capacity significantly or cause overheating.

3. Discharging Temperature

The Discharging Temperature must be within the range specified in this Specification Approval Sheet.

4. Over-Discharge

Over-discharging will cause cell degradation and functional losses. The cell can degrade into an over-discharge state through self discharging. In order to prevent over-discharging, the cell should be charged periodically to retain between 3.2V and 3.4V.

5. Protective Circuit Module

5.1 The cell/battery pack shall contain a PCM that can protect the cell/battery pack properly.

The PCM shall have functions of:

- (1) Overcharging prevention
- (2) Over-discharging prevention
- (3) Over current prevention to maintain safety and prevent significant deterioration of cell performance. Over current can occur by an external short circuit which circumvents the PCM.

5.2 Overcharging Protection

Overcharging prevention stops charging if any cell of the battery pack reaches 3.85V.

5.3 Over-discharging protection

The Over-discharging protection monitors the voltage of every cell in

POLYMER LITHIUM BATTERY DATA SHEET

FILE No.: **GMB021709/LIPO**

the pack and works to avoid a drop in the cell voltage to 1.8V or less.

6. Storage

Cells should be stored at the proper temperature that is identified in the Specification Approval Sheet.

7. Notice△

7.1 Handling of cells:

- ★ Avoid any short-circuit. It will cause the leads to get hot and lose electronic functions.
- ★ Soft package is easily damaged by sharp objects such as needles and knives. Avoid touching the cells with sharp objects when handling and storing.
- ★ Next to the leads is the sealed edge. Don't bend or fold the sealing edge as it is sensitive to movement.
- ★ Don't open the folded edge on the sides of the cell.
- ★ Don't bend the tabs as the tabs are sensitive.
- ★ Avoid mechanical shock to the cells.
- ★ Don't put the cells into an oven, washing machine or any high-voltage container.
- ★ Don't use a charger without a safety certification. Use only a recommended charger.
- ★ You should immediately stop charging if the cell overheats, emits an odor, changes color, changes shape, etc.
- ★ Adults should supervise the use of batteries by children.
- ★ Before using batteries, please carefully read and understand the handling guidelines.
- ★ Avoid electro-static discharge when using, charging, and storing cells. Avoid putting the battery in contact with metal conductors such as neck chains, barrettes, or bolts, etc.
- ★ Don't use metal conductors to connect the positive and negative leads together.
- ★ Avoid errors during assembly by contacting the positive lead with the negative lead.

7.2 Notice for Designing Battery Pack

7.2.1 Package Design

- The battery pack should have sufficient strength and the battery should be protected from mechanical shock.
- No sharp objects should be inside the pack containing the battery.

7.2.2 PCM Design

- The overcharge threshold voltage should not exceed 3.7V (single pack).
- The over-discharge threshold voltage should not be lower than 1.8V (single pack).

POLYMER LITHIUM BATTERY DATA SHEET

FILE No.: **GMB021709/LIPO**

- The PCM should have short circuit protection.

7.3 Notice for Assembling Battery Pack

7.3.1 Tab connection

- Ultrasonic welding or spot welding is recommended to connect the battery with the PCM or other parts.
- If the tab is to be soldered to the PCM, the instructions below are very important to ensure battery performance.
 - a. The solder iron should be temperature controlled and ESD safe.
 - b. Soldering temperature should not exceed $360 \pm 10^\circ\text{C}$.
 - c. Soldering time should not be longer than 3 seconds.
 - d. Let the battery tab cool down before soldering again.
 - e. Direct heat to the cell body is strictly prohibited. The battery will be damaged by heat above approx. 60°C .

7.3.2 Cell fixing

- (1) The cell should be fixed to the battery pack by its large surface area.
- (2) There should be no sharp edges at the assembly contact area.
- (3) Cells must be held firmly in the battery pack; movement is not allowed.

8. Others

8.1 Disassembly may cause an internal short circuit to the cell, which may cause out-gassing, fire, or other problems.

8.2 Prohibition of dumping of cells into fire

Never incinerate or dispose of the cells in a fire as this may cause the cells to catch fire.

8.3 The cells should never be exposed to liquids such as water, drinks or oil.

8.4 Do not mix the cells from different manufacturers in a common pack. Do not mix new cells with old ones.

▲ Special Notice: If the cell isn't used for a long time, please keep the cells in a half-charged state neither fully charged and not completely discharged. Recharge the cells and use half of the power after 2-3 months. Store the cells in a cool and dry place. It will protect the cell from damage.