



GUANGZHOU MARKYN BATTERY CO., LTD.

## Specification Approval Sheet

Product Name	Li-ion Battery
Model SPEC	LFP26650C3/12Ah/36V
Company Name	GMB POWER
Document Number	GMB1112005
Sample Number	
Document Revision	A0

Approved By	Checkup	Make

Customer Confirmation	Signature	Date
	Company Name:	
	Company Stamp:	





## Content

1. Scope.....	4
2. Products specified .....	4
3. Caution .....	4
4. Basic characteristics .....	5
5. Protective Circuit Module.....	5
6. Standard conditions for test.....	5
7. Appearance .....	6
8. Characteristics .....	6
9. Others.....	8
10. Drawing.....	9

**Any copies are invalid without our company's approval**

## 1. Scope:

This specification describes the technological parameters and testing standard for the lithium ion rechargeable cell manufactured and supplied by Guangzhou Markyn Battery Co., Ltd.

The temporary specification is only for the customer's reference, not regarded as the basis of the IQC and mutual confession.

## 2. Products specified

- 2.1. Name Cylindrical Lithium Ion Rechargeable Cell
- 2.2. Type LFP26650-3000mAh

## 3. Caution:

- 3.1 Please read these specifications carefully before testing or using the cell as improper handling of a Li-ion cell may result in lose of efficiency, heating, ignition, electrolyte leakage or even explosion.
- 3.2 While testing the cell by charging and discharging, please use test-equipment especially designed for Li-ion cell. Do not use ordinary constant current and constant voltage (CC/CV) power supplies. These do not protect the cell from being overcharged and over-discharged, resulting in possible loss of functionality or danger.
- 3.3 When charging and discharging cells or packing them into equipment, reversing the positive and negative terminals will result in overcharging and over-discharging of the cell(s). This could lead to serious loss of efficiency and even explosions.
- 3.4 Do not solder directly on the cell. Do not resolve the cell.
- 3.5 Do not put cell(s) in pockets or bags together with metal products such as necklaces, hairpins, coins, screws, etc. Neither stores them together without proper isolation. Do not connect the positive and negative electrode directly with each other through conductive materials. This can result in a short circuit of the cell.
- 3.6 Do not beat, throw or trample the cell, do not put the cell into washing machines or high-pressure containers.
- 3.7 Keep the cell away from heat sources such as fires, heaters, etc. Do not use or store cell(s) at locations where the temperature can exceed 60such as in direct sunlight. This may lead to the generation of excessive heat, ignition and lose of efficiency.
- 3.8 Do not get cells wet or throw them into water. When not in use, place the cells in a dry environment at low temperatures.
- 3.9 While during use, testing or storing cells, cells become hot, distribute a smell, change color, deform or show any other abnormalities, please stop using or testing immediately. Attempt to isolate the cell and keep it away from other cells.

ADD: Block2, Haijin Road6, Markyns Industrial Zone, XinZao Town, Panyu District, Guangzhou City, P.R.C.

Tel: 0086-20-34729558-603 Fax: 0086-20-34725531

3.10 Should electrolyte get into the eyes, do not rub the eyes, rinse the eyes with clean water and seek medical attention if problems remain. If electrolyte gets onto the skin or clothing, wash with clean water immediately.

3.11 Don't charge the cells and keep them in a charged state for a long time.( Display units should dismantle the battery)

## 4. Basic characteristics

### 4.1 PACK parameters

NO.	Items	Required Parameters	Remarks
1	Nominal Capacity	12000 ± 400 Ah	NA
2	Nominal Voltage	DC: 38.4 V (3.2 V/Cell × 12 S)	The average voltage in the process of standard discharging.
3	Standard Charging Method	Charge and discharge at Constant Current、constant voltage .	NA
4	Charging Cut-off Voltage	≤ 43.2 V	NA
5	Discharging Cut-off Voltage	≥ 30.0 V	NA
6	Maximum Charging Current	6.0 A	NA
7	Maximum Discharge Current	36A (C <sub>3</sub> A)	NA
8	Maximum Pulse Discharge Current	60 A/2 S (C <sub>5</sub> A)	NA
9	Weight	≈ 4.85 Kg	Charger excluded
10	Storage Temperature	-20 °C ~ 40 °C	NA
11	Storage Humidity	25%~95% RH	NA
12	Temperature	Charge	0 °C ~ 45 °C
		Discharge	-20 °C ~ 55 °C

## 5. Protective Circuit Module

### 5.1 The cell/battery pack shall contain a PCM that can protect the cell/battery pack properly.

The cell/ battery shall be provided with a PCM to protect the cell/ battery properly.

PCM shall have the following functions to ensure safety and prevent deterioration of cell performance:

- (1) Measure pack and cells parameters
- (2) Protect cells from abuse
- (3) Optimize cells working conditions
- (4) Cell balancing
- (5) Over-charging prevention
- (6) Over-discharging prevention
- (7) Over-current prevention.

### 5.2 Overcharging Protection

Overcharging prevention stops charging if any cell of the battery pack reaches 3.90V.

### 5.3 Over-discharging protection

The Over-discharging protection monitors the voltage of every cell in the pack and works to avoid a drop in the cell voltage to 2.0V or less.

## 6. Standard conditions for test

All the tests need to be done within one month after the delivery date under the following conditions :

Ambient Temperature:  $23 \pm 1^\circ\text{C}$ ; Relative Humidity: 35~75%

a) Standard Charge	Constant Current and Constant Voltage (CC/CV) Current = 0.2C Final charge voltage = 3.65V Final charge Current = 0.02C
b) Standard Discharge	Constant Current (CC) Current = 0.2C End Voltage = 2.0V

## 7. Appearance

All surfaces must be clean, without damages, leakage and corrosion. Each product will have a product label identifying the model.

## 8. Characteristics

### 8.1 Electrical Performances

Items	Test Procedure	Required Parameters
Standard charge	1) 0.5C charge till single cell voltage reaches 3.65V; 2) turn to 3.65V constant voltage charge till charge current decline to 0.03C.	N/A
Quick Charge	1) 1.0C current constant charging till single cell voltage reaches 3.65V; 2) turn to 3.65V constant voltage charge till charge current decline to 0.03C.	N/A
Shipment Voltage	Inspection before out shipment	$\geq 3.28V$
Nominal Capacity	1) 0.5C constant current discharge till voltage to 2.50V before charging; 2) Standard charge and then lay for 10 minutes; 3) Discharge capacity when 0.5C discharge till the voltage reaches 2.50V.	$\geq 100\%$ Nominal Capacity
Quick Discharging capacity	1) 1C constant current discharge till voltage to 2.50V before charging; 2) Standard charge and then lay for 10 minutes; 3) Discharging capacity at 1C discharge till 2.50V	$\geq 95\%$ Nominal Capacity
Cycle life	1) Battery discharged according to standard discharging requirements and then lay for 10 minutes 2) Battery charging according to standard charging requirements and then lay for 10 minutes 3) discharge at 1C till battery voltage reaches cut-off voltage 2.50V. Cycle charging and discharging according to 2) and 3), cycle ends when any of the discharging capacity < 80% nominal capacity.	$\geq 2000$ times
-20°C Discharging capacity	Fully charged at room temperature and lay for more than 6 hours at -20°C, then 0.5C discharge till the voltage reaches 2.50V	$\geq 55\%$ Nominal Capacity
-20°C Charging capacity	Fully discharged at room temperature and lay for more than 6 hours at -20°C, then 0.2C charge till the voltage reaches 3.65V.	$\geq 60\%$ Nominal Capacity
55°C Discharging capacity	Fully charged battery at room temperature and lay for more than 6 hours at 55°C, 1 C discharge at 23±2°C till the voltage reaches 2.50V.	$\geq 100\%$ Nominal Capacity

## 8.2 Safety Performances

Item	Test Procedure	Criteria
Vibration	SOC 100% battery vibrate for 2 hours on the vibration platform in the condition of: Frequency: 30Hz - 35Hz Acceleration: 30m/s <sup>2</sup>	No fire, explosion and leak with battery's internal impedance change < 0.5mΩ
Drop	SOC 100% battery is to be dropped from a height of 1m onto a 5cm thick hard wood floor including positive pole, negative pole drop and horizontal direction drop with each tested for twice.	No fire, explosion and leak with battery's internal impedance change < 0.5mΩ
Heating	Put the SOC 100% battery into the oven with circulating air or gravity-convection and heat it at a speed rate of 5±2°C/min to 135±2°C and remain for 10 minutes at the temperature.	No fire, explosion
Short Circuit	Connect the positive and negative terminals of SOC 100% battery which connecting to thermocouples with a maximum resistance load of 50 mΩ; Monitor the temperature of the cell until it is 10°C lower than the peak temperature.	No fire, no explosion Temperature < 150° C
Over Charging	1) Standard discharge and then lay for 10 minutes; 2) Standard charge and then lay for 10 minutes; 3) 1C current charge to 10.0V(All is acceptable under 30V charging )	No fire, no explosion
Impact	1) Put a ø15.8mm steel bar across the center of the fully charged battery 2) Drop a 10Kg weight iron hammer from a height of 1.0m onto the sample	No fire, no explosion
Nail Pricking	Penetrate an ø 2.5mm steel nail into the cell directly at the speed of 10~40mm/s	No fire, no explosion

## 9.0 Others

### 9.1 Package

When packing. Product name、 model 、 nominal voltage、 quantity、 gross weight、 date of production and corresponding impedance、 capacity should be marked outside the package box.

ADD: Block2, Haijin Road6, Markyns Industrial Zone, XinZao Town, Panyu District, Guangzhou City, P.R.C.

Tel: 0086-20-34729558-603 Fax: 0086-20-34725531



### **9.2 Transport**

The cell should be packed in box for transport, avoid acute vibration, shock or extrusion, exposed to the sun and rain during transport. We can use car, train, ship and plane for transport.

### **9.3 Storage**

The cell should be placed in a clean and dry room where the temperature is specified in 4.14 and the relative humidity is less than 75%, avoid contacting with corrosive substances, away from fire and heat resource. Besides, keep the cell in a half-charged state to prevent self-discharge

### **9.4 Repair period is 12 months after leaving the factory.**

### **9.5 we will take no responsibility for any accident when the cell is used under conditions outside of this specification**

### **9.6 Any issues not covered in this specification should be discussed between the customer and us.**

## 10. Drawing

### 10.1 Cell Drawing (Not in scale)

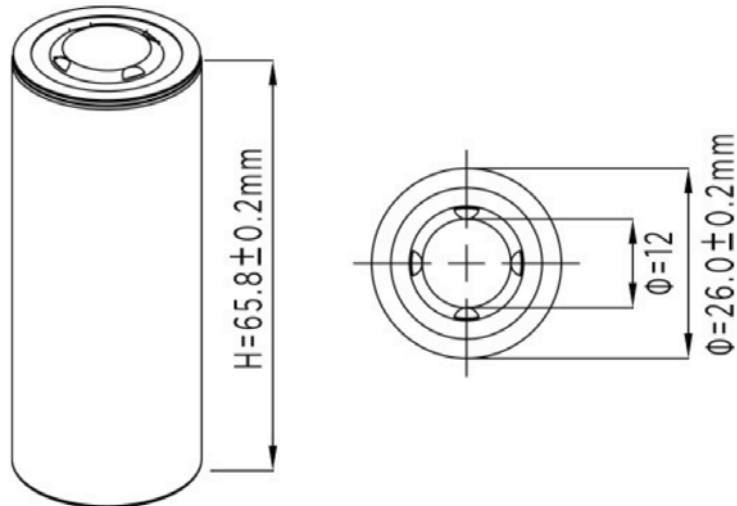

### 10.2 Dimension

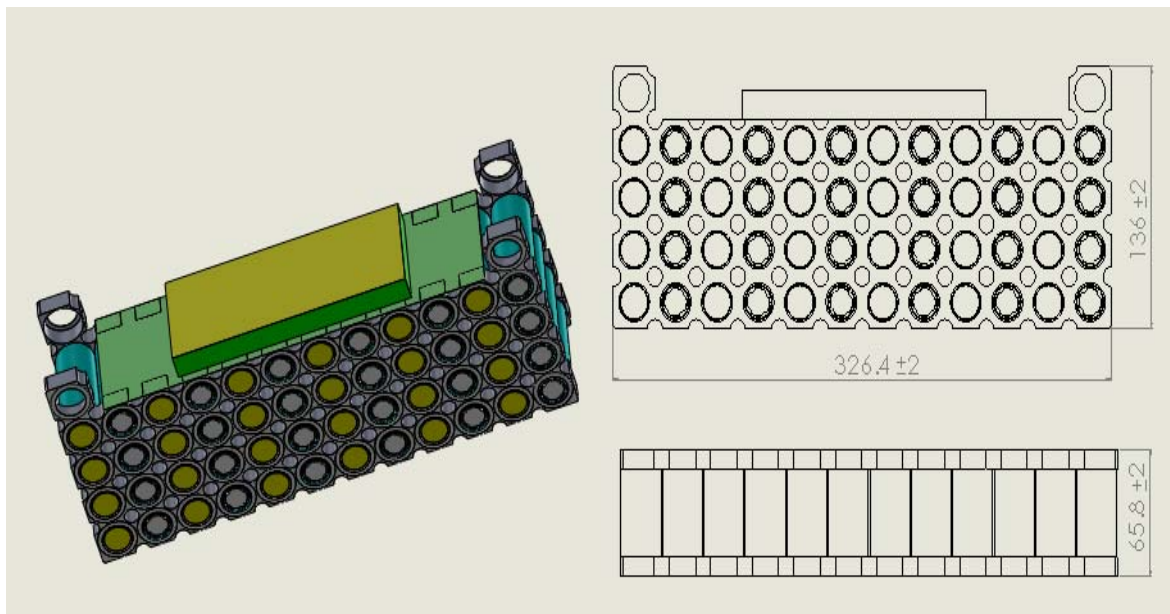

## 11. BMS Specification(Ta=25°C)

序号	功能	分类功能	功能参数
1	Voltage	charging voltage	DC:43.2V 3.6V/Cell
		Balance starting voltage	3.60V ± 0.025V
2	Current	Balance current of single cell	72mA ± 10mA
		Maximum discharging current(cont.)	≤ 35A
3	Over-charge Protecting	Over-charge detection voltage	3.90V ± 0.025V
		Over-charge detection delay time	0.96S - 1.4S
		Over-charge recovery voltage	3.80V ± 0.05V
4	Over-discharge Protecting	Over-discharge detection voltage	2.00V ± 0.05V
		Over-discharge detection delay time	115mS - 173mS
		Over-discharge recovery voltage	2.3V ± 0.05V
5	Discharge Over-current protection	Discharge Over-current protection voltage	0.62V
		Discharge Over-current protection current(cont.)	65A ± 5A
		Discharge Over-current detection delay time	≤ 2S
		Discharge Over-current recovery	Load leave
6	Short-circuit protection	Short-circuit detection delay time	200 us - 500us
		Discharge Over-current recovery	Load leave
7	Resistance	MOSFET	≤ 40mΩ
8	Temperature	-40~+85°C	